

Electrochemical molecular recognition: pathways between complexation and signalling

Paul D. Beer,^{*a} Philip A. Gale^{*a} and George Z. Chen^{*b}

^a Department of Chemistry, University of Oxford, Inorganic Chemistry Laboratory, South Parks Road, Oxford, UK OX1 3QR

^b Department of Materials Science and Metallurgy, University of Cambridge, Pembroke St., Cambridge, UK CB2 3QZ

Received 22nd February 1999, Accepted 26th March 1999

This perspective examines the mechanisms by which electrochemical recognition of various charged and neutral guest species by redox-active receptor molecules takes place. Particular emphasis is given to the intramolecular signalling pathway employed in each case. These include electrostatic interactions (through space or through conjugated bonds), conformational changes in the redox centre, participation of the redox centre in complexation and guest interference to an already present communication pathway in the host.

1 Introduction

Electrochemical molecular recognition is a fast expanding research area at the interface of electrochemistry and supra-

molecular chemistry. The aim of this area of chemistry is the development of highly selective and sensitive electrochemical sensors for charged or neutral target guest species. Two strategies have been applied to the electrochemical detection of host-guest complex formation; extraction of a charged guest into a membrane and detection of the resultant membrane potential, or detection of a perturbation of the host's properties on complex formation. The former method comprises an ion selective electrode (ISE)¹ in which a membrane containing the receptor separates an internal solution and a further reference electrode. The half potentials of both the reference electrodes are known thus enabling calculation of the membrane potential that is a function of analyte concentration. Alternatively, the membrane potential may be measured by a solid state device known as a Chemically Modified Field Effect

Professor Paul D. Beer was born in Totnes, Devon. In 1979 he obtained a first class honours degree in chemistry from King's College London, and remained there to undertake research in the field of organophosphorus chemistry under the supervision of Dr. C. D. Hall. In 1982 he received a Ph.D. and a Royal Society postdoctoral fellowship enabled him to conduct research in supramolecular chemistry with Professor J.-M. Lehn at the Université Louis Pasteur, Strasbourg, France. After a demonstratorship at the University of Exeter in 1983, in 1984 he took up a New Blood Lectureship at the University of Birmingham. In 1990 he moved to the University of Oxford, where he is also a tutorial fellow at Wadham College. He became a professor of chemistry in 1998. He was awarded in 1987 the RSC Meldola medal, in 1993 the UNESCO Javed Husain prize and in 1994 the RSC Corday-Morgan medal. His research interests cover many aspects of charged and neutral guest co-ordination chemistry, including the synthesis and co-ordination properties of redox- and photo-responsive receptors designed selectively to recognise and sense biological and environmentally important guest species.

Dr. Philip A. Gale was born in Liverpool. In 1992 he graduated with a B.A. (Hons.) in chemistry from Wadham College, Oxford. He remained in Oxford (moving to Linacre College) to undertake research in calixarene chemistry under the supervision of Professor P. D. Beer, graduating in 1995 with an M.A. and a D.Phil. In October 1995 he joined Professor Jonathan L. Sessler's research group at the University of Texas at Austin as a Fulbright postdoctoral fellow where he studied the anion co-ordination properties of calixpyrrole macrocycles. In October 1997 he took up a Royal Society University Research Fellowship at the Inorganic Chemistry Laboratory,

Oxford. His research interests include the synthesis of new self-assembling receptor molecules. He is the author or co-author of over forty publications including a patent, several review articles and an Oxford Chemistry Primer (Supramolecular chemistry, co-authored with Paul Beer and David Smith).

Dr. George Zheng Chen was born in Jiangxi Province, P.R. China. He obtained a Diploma in Chemistry from Jiujiang Teacher Training College (P.R. China) in January 1981. Supervised by Professors Q. Zhang and W. J. Albery respectively, he was awarded the degrees of M.Sc. by Fujian Teachers University in January 1985 and of Ph.D. by the University of London in June 1992, and also the Diploma of Imperial College of Science, Technology and Medicine. Since then he has carried out his postdoctoral work in the Universities of Oxford (associated with Professor P. D. Beer), Leeds and Cambridge (associated with Professor D. J. Fray). His research experience covers Physical, Inorganic and Materials Chemistry. He is the co-author of thirty publications and two patents.



Philip A. Gale

Paul D. Beer

George Zheng Chen

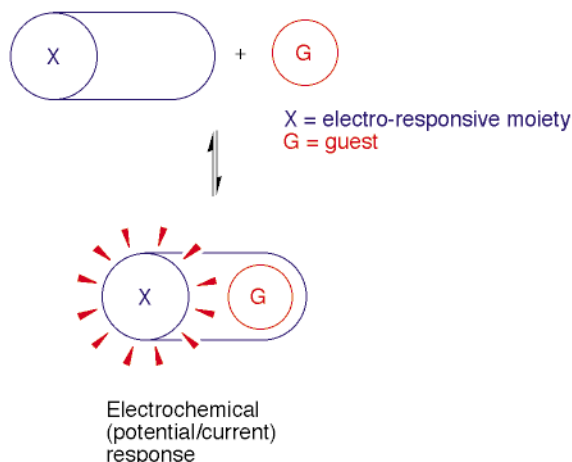
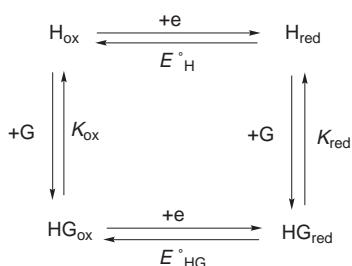

Fig. 1 The presence of a guests species G triggers an electrochemical response in a host molecule.

Transistor (CHEMFET).² This is similar to the ISE except that the membrane is attached to the gate of a field effect transistor.

The second strategy is the subject of this review and is shown schematically in Fig. 1. The receptor has a binding site and a 'reporter group' in close proximity. The reporter group is chosen to have well behaved electrochemical properties (*e.g.* ferrocene) that are perturbed upon guest complexation. Such systems can be described by the scheme of squares shown (Scheme 1) where H, G and HG represent the host, guest and



Scheme 1 The scheme of one square for guest binding and electron transfer.

complex species respectively, subscripts "ox" and "red" indicate that the corresponding molecules or parameters are in oxidised and reduced states, E° is the formal potential of the electron transfer reaction and K is the stability constant. The stability constant K of a host/guest (1:1) complex is defined by the equilibrium shown in Scheme 1.

The four reactions in Scheme 1 constitute a closed route, therefore the total Gibbs free energy change in this cycle is zero. If we consider equilibrium to be approached *via* a clockwise route starting from H_{ox} , the above statement can then be mathematically expressed as in eqn. (1). Rearranging (1) leads

$$\begin{aligned} \Sigma \Delta G = \Delta G_H + \Delta G_{red} + \Delta G_{HG} + \Delta G_{ox} = 0 \\ nF(E - E^\circ_H) - RT \ln(K_{red}) + nF(E^\circ_{HG} - E) + \\ RT \ln(K_{ox}) = 0 \quad (1) \end{aligned}$$

to eqn. (2). Eqn. (2) links, in a simple way, the thermodynamic-

$$nF(E^\circ_{HG} - E^\circ_H) = RT \ln(K_{red}/K_{ox}) \quad (2)$$

ally important stability constants K_{ox} and K_{red} of a complex in different oxidation states with experimentally measurable redox potentials E°_H and E°_{HG} . Obviously, receptors designed electrochemically to recognise guest species must be able to respond to the binding of the guest with a significant change in their redox potentials. In practice, gauged by experimental error, the mini-

imum measurable potential difference is for example about ± 5 mV in voltammetric methods. To achieve a significant perturbation, the receptor should be able to couple its complexation to the redox reaction *via* one or a combination of several coupling pathways. In other words, the receptor must have a structure such that upon guest binding the electron transfer to or from the receptor's redox centre is achieved at a significantly different potential from that of the receptor in the absence of the guest species.

The quotient K_{red}/K_{ox} is a theoretically useful parameter because it allows not only the calculation of K_{red} if K_{ox} is known and *vice versa*, but also the evaluation of the effect of electron transfer on the complexation. Some authors have termed it the binding enhancement factor (BEF)³ when considering some reducible and cation-binding receptors as molecular switches. However, guest binding by a redox active molecular receptor is not always enhanced upon electron transfer (either oxidation or reduction). For example, in the simplest case where the guest and electron transfer reactions are coupled by purely through space electrostatic interaction, oxidation (electron withdrawn from the receptor) will weaken cation binding but enhance anion binding, whilst the opposite is true for reduction (electron insertion to the receptor). For this reason, we have proposed that a better description for this quantity would be the reaction coupling efficiency (RCE).^{18b} Regardless of the direction, the further away the quotient is from unity, the more efficient is the coupling between the guest binding and electron transfer reactions, and therefore the greater the intramolecular signal transferred between the bound guest and the redox centre.

Although demonstrating the importance of the RCE, eqn. (2) does not indicate how a desired RCE may be achieved. The presence of an intramolecular signalling pathway linking the binding site and redox-active centre is essential to produce an effective redox-active sensor molecule. These pathways include (Fig. 2): (a) through space electrostatic interaction between the redox centre(s) and the complexed guest molecule; (b) through bond communication provided typically by conjugated chemical bond linkage between the redox centre(s) and the binding cavity; (c) additional direct co-ordination bond formation between the redox centre and the complexed guest molecule; (d) conformationally induced perturbation of the redox centre(s) caused by the complexation of a guest molecule; and (e) interference by the guest species in communication between two redox-active centres.

Echegoyen and co-workers⁴ have recently published an extensive review of the electrochemical properties of a wide range of supramolecular systems. The purpose of this perspective is not to provide a comprehensive review of supramolecular electrochemistry but rather to illustrate the role each of the binding-redox pathways can play in electrochemical molecular recognition processes. This will be achieved by highlighting selected redox-responsive receptor examples from the literature.

2 The through space electrostatic interaction mechanism

Should an electrostatic interaction be the only intramolecular interaction as a result of guest binding, the change in energy in a mole of the complex upon electron transfer can be expressed by eqn. (3) according to electrostatics, where N_A is the Avogadro

$$W = N_A Q_{\text{guest}} \Delta Q_{\text{redox}} / 4\pi\epsilon_0\epsilon d \quad (3)$$

constant, Q_{guest} the effective charge on the bound guest, ΔQ_{redox} the change in effective charge on the redox centre, ϵ_0 the vacuum permittivity, ϵ the relative permittivity of the medium, and d the distance between the redox centre and the bound guest. Combining eqn. (3) with (2) will allow the establishment of a direct relation between the complexation induced potential change ($E^\circ_{HG} - E^\circ_H$) with the guest's effective charge. Using

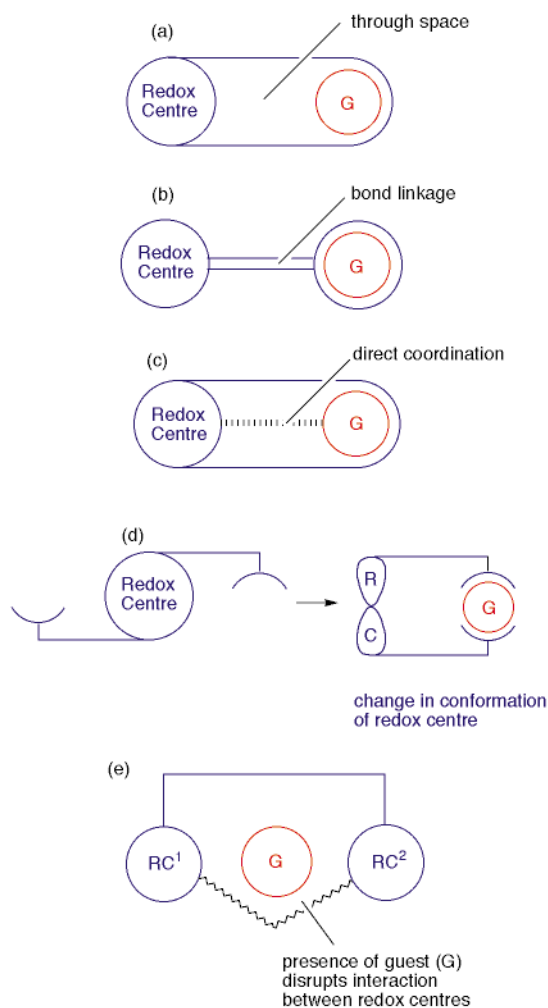

Fig. 2 The five mechanisms for coupling complexation and redox reactions.

the relation $\Delta G = RT \ln K$, we find that the right hand side of eqn. (2) is the difference in the Gibbs free energy between the reduced and oxidised complexes, *i.e.* eqn. (4).

$$RT \ln (K_{\text{red}}/K_{\text{ox}}) = \Delta G_{\text{red}} - \Delta G_{\text{ox}} \quad (4)$$

Since the only energy difference between the reduced and oxidised complexes is the electrostatic energy represented by eqn. (3), eqn. (2) can now be rewritten as eqn. (5).

$$nF(E^{\circ}_{\text{HG}} - E^{\circ}_{\text{H}}) = N_{\text{A}}Q_{\text{guest}}\Delta Q_{\text{redox}}/4\pi\epsilon_0\epsilon d \quad (5)$$

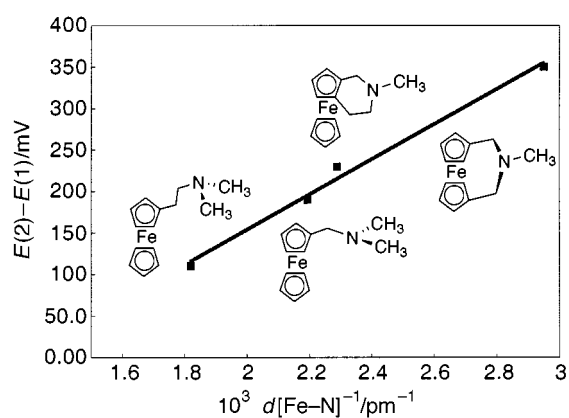

Fig. 3 A plot of the inverse Fe–N distances in four ferrocene amines against the differences of the redox couples of ligands in their free and protonated forms.

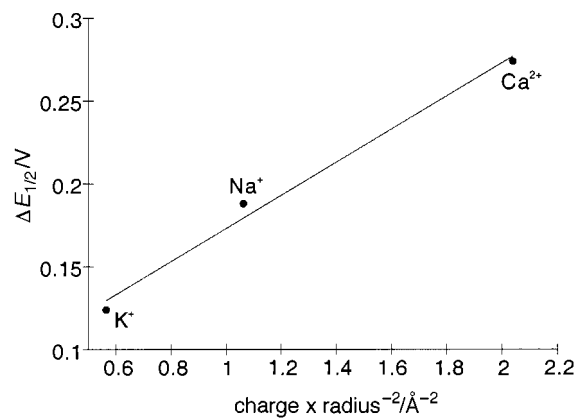
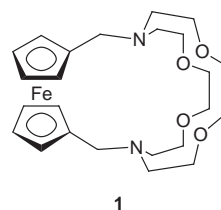

Fig. 4 A plot of $\Delta E_{1/2}$ vs. charge/(radius)² ratio for the complexation of Na⁺, K⁺ and Ca²⁺.

In fact, Plenio and Diodone⁵ have applied this approximation to more than twenty ferrocene nitrogen compounds in which a proton may be regarded as the guest cation. Fig. 3 presents the linear correlation between the anodic shift in potential and the distance between the proton and ferrocene. The accuracy of the approximation is satisfactorily high. Anodic shifts are observed in these systems because, once protonated, the ferrocene compound becomes harder to oxidise and therefore the ferrocene–ferrocenium couple shifts to a higher potential.



1

In earlier work, Gokel and co-workers³ studied the electrochemical properties of the ferrocene cryptand molecule **1** by cyclic voltammetry. Gokel found a linear correlation between $\Delta E_{1/2}$ and the charge/(radius)² of several Group 1 and 2 cationic guests added to a solution of the receptor (Fig. 4). Addition of substoichiometric amounts of NaClO₄ to the electrochemical solution of the ligand caused the appearance of a new set of waves at 0.402 V vs. SSCE [Fig. 5(a) and (b)]. The currents for the new redox couple increase linearly with the concentration of Na⁺ ion until a single equivalent is added. At this point the waves corresponding to “free” ligand have disappeared and the cyclic voltammogram corresponds to the oxidation of the pure complex. This two wave behaviour^{6,7} has been rationalised in terms of the high stability constant of the **1**·Na⁺ complex. Slow decomplexation kinetics were discounted on the basis that no change in the cyclic voltammogram of an electrochemical solution of compound **1** in the presence of 0.5 equivalent Na⁺ cations was observed when the scan rate was varied between 0.02 and 5 V s⁻¹.

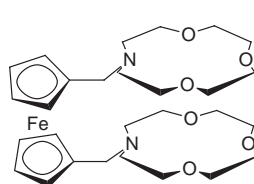

2

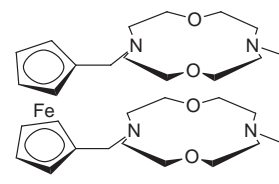

3

Electrochemical metal cation recognition studies of compounds **2** and **3** reveal that these receptors exhibit Li⁺ selectivity.⁸ Upon addition of sodium or lithium cations to electrochemical solutions of **2** or **3** there are significant anodic

Table 1 Anodic shifts in the redox couples of compounds **2** and **3** upon addition of Li^+ or Na^+ cations

	Compound 2	Compound 3
$\Delta E(\text{Li}^+)/\text{mV}$	+100	+140
$\Delta E(\text{Na}^+)/\text{mV}$	+70	+100

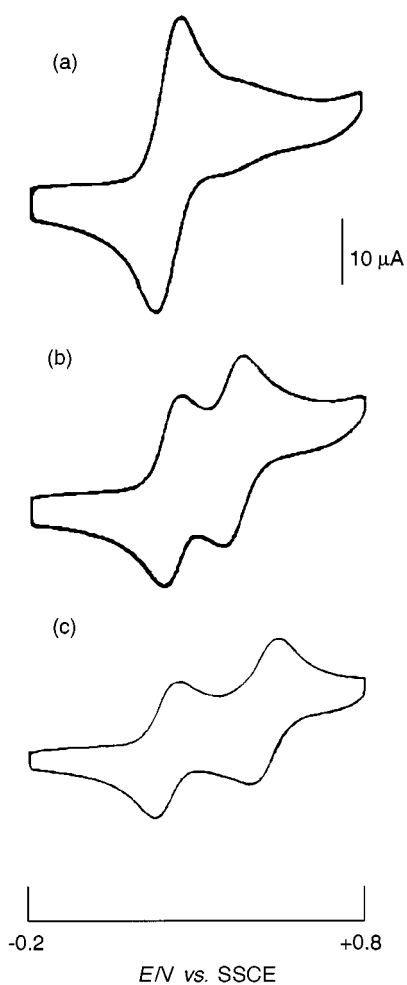

Fig. 5 Voltammetric response of acetonitrile solutions of 1.0 mmol dm^{-3} **1**: (a) stationary glassy carbon electrode (0.08 cm^2), scan rate 100 mV s^{-1} ; (b) same conditions as (a) with 0.5 equivalent NaClO_4 added; (c) same conditions as (a) with 0.5 equivalent Ag^+ added. (Reprinted with permission from ref. 3, Copyright 1992, American Chemical Society.)

shifts of the redox potentials of the receptors (Table 1). Interestingly, addition of cations to **3** caused the electrochemical behaviour to become reversible at room temperature. The highly selective co-ordination of lithium cations by **3** can be used to detect Li^+ electrochemically in the presence of large excesses of these other Group 1 cations.

Echegoyen and co-workers⁹ have recently reported that the electrochemical properties of crown-ether modified fullerenes are perturbed by the presence of alkali metal cations. Compounds **4**, **5** and **6** were synthesized by a Bingel macrocyclisation of C_{60} with a bis-malonate containing a dibenzo-18-crown-6 tether. The electrochemical properties of these materials were studied in ion-selective electrodes as well as in solution. Fig. 6 shows a cyclic voltammogram for **4** in the absence and presence of ten equivalents of KPF_6 . The first reduction processes occurring in the fullerene shift anodically by 90 mV upon addition of potassium due to the through space electrostatic influence of the bound cation. The redox potentials of all three receptors in the absence and presence of potassium cations are shown in Table 2.

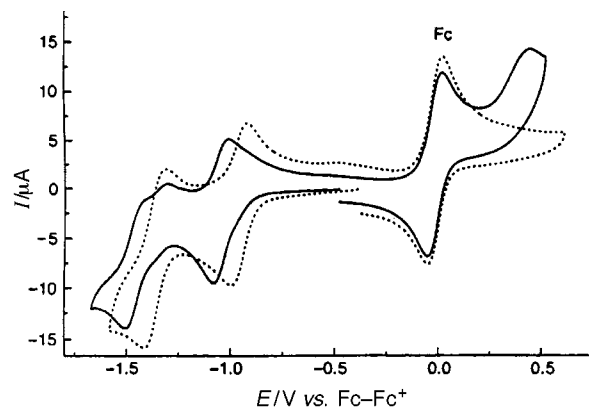
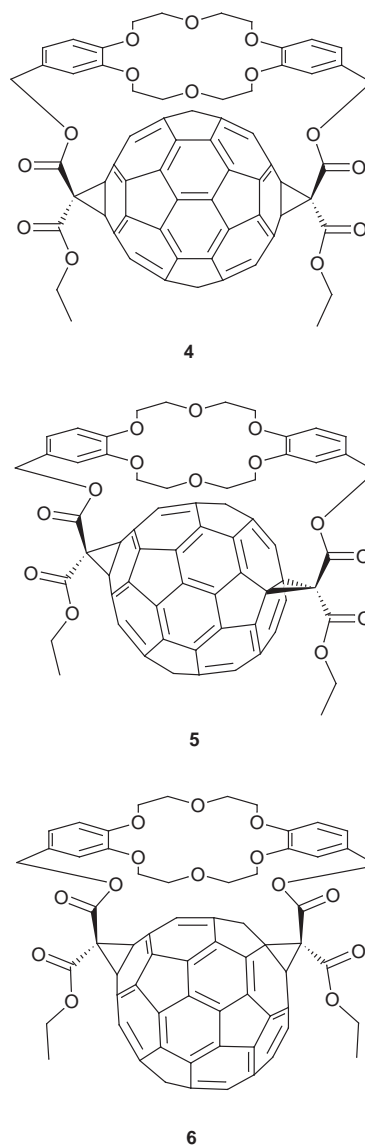

Fig. 6 Cyclic voltammograms for (\pm)-**4** recorded at 100 mV s^{-1} on a glassy carbon mini-electrode: solid line, solution of free (\pm)-**4** with one equivalent of cryptand 222 (4,7,13,16,21,24-hexaoxa-1,10-bicyclo-[8.8.8]hexacosane) present; dotted line, solution of (\pm)-**4** with ten equivalents of KPF_6 . (Reprinted with permission from ref. 9, Copyright 1998, Wiley-VCH.)



The detection of two different cations simultaneously by a single redox-active receptor has recently been achieved. Beer *et al.*^{10,11} found that receptor **7**, which contains two metal binding sites, could be used to sense the presence of barium, magnesium, or a mixture of barium and magnesium *via* a through space interaction. Unique three peak voltammetric

Table 2 Redox potentials (V vs. Fc–Fc⁺) for compounds (±)-4–(±)-6^a

Compound	+ cryptand 222 ^b		+ KPF ₆ ^c	
	<i>E</i> _{1/2} ¹	<i>E</i> _{1/2} ²	<i>E</i> _{1/2} ¹	<i>E</i> _{1/2} ²
(±)-4	–1.04 (70)	–1.51 ^d	–0.95 (79)	–1.36 (104)
(±)-5	–1.02 (79)	–1.48 ^d	–0.97 (75)	–1.43 ^d
(±)-6	–1.05 (83)	–1.47 ^d	–1.01 (77)	–1.46 ^d

^a In MeCN–CH₂Cl₂ (1 : 1) in the presence of 0.1 M *n*-Bu₄NPF₆; Fc–Fc⁺ was used as the internal reference, and measurements were made with a glassy carbon working mini-electrode. Values for Δ*E*_{pp} are given in parentheses. ^b One equivalent. ^c Ten equivalents. ^d Only the cathodic potential is given.

features are observed for **7** in the presence of both Mg²⁺ and Ba²⁺, which correspond to the three complexes 7·2Ba²⁺, 7·2Mg²⁺ and 7·Ba²⁺·Mg²⁺ anodically shifted from free **7** by 150, 395 and 275 mV respectively.

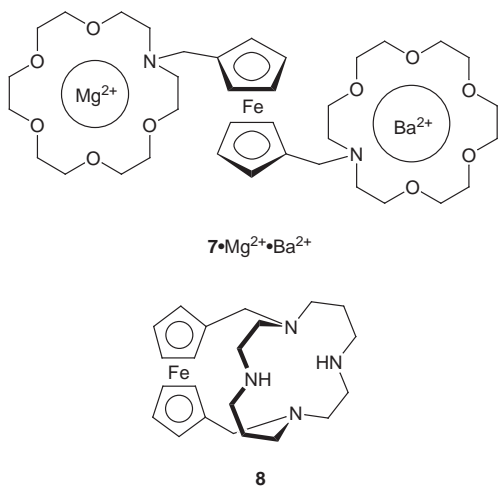

Electrochemical recognition is not limited to Group 1 or 2 metal cations. Various groups have produced receptors that are capable of recognising transition metals.^{12–14} In a recent example, Plenio and Aberle¹⁵ have reported the synthesis of a ferrocene-bridged cyclam **8** that exhibits large changes in redox properties in the presence of transition metal cations. The crystal structure of the Ni(CF₃SO₃)₂ complex (Fig. 7) reveals that the nickel is bound at a distance of 3.854(8) Å from the Fe atom. The electrochemical properties of **8** in the presence of various transition metal cations (Table 3) reveal large perturbations of the ferrocene–ferrocenium, mediated by through space electrostatic interactions although Plenio does not completely discount the possibility that there may be a direct co-ordination pathway between the iron atom of the ferrocene moiety and the transition metal guest.

A number of systems that are capable of sensing transition

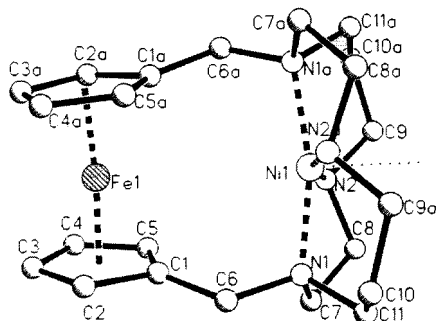
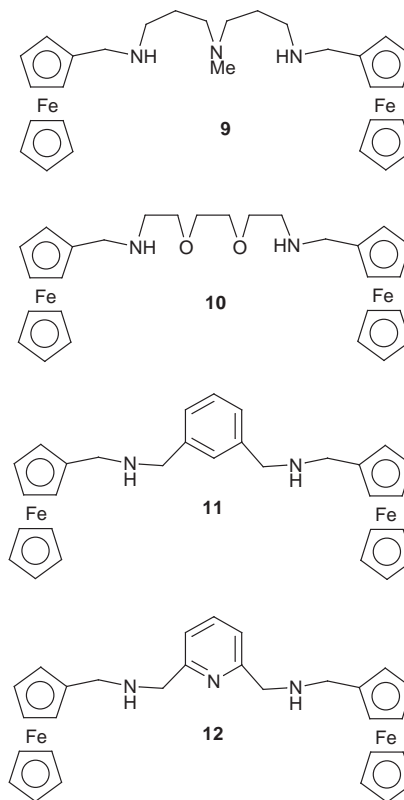

Fig. 7 Crystal structure of the Ni(CF₃SO₃)₂ complex of receptor **8**. (Reprinted with permission from ref. 15, Copyright 1998, Royal Society of Chemistry.)

Table 3 Electrochemical data of compound **8** and transition metal complexes as determined by cyclic voltammetry in MeCN using *n*-Bu₄NPF₆ as supporting electrolyte vs. cobaltocene (*E*_{1/2} = –0.94 V) or ferrocene (*E*_{1/2} = +0.40 V) reference

Compound	<i>E</i> _{1/2} /V (Fe ^{II} –Fe ^{III})	Δ <i>E</i> _{1/2} /mV
8	+0.33	—
8 ·Co(CF ₃ SO ₃) ₂	+0.69	+360
8 ·Ni(CF ₃ SO ₃) ₂	+0.71	+380
8 ·Cu(CF ₃ SO ₃) ₂	+0.74	+410
8 ·Zn(CF ₃ SO ₃) ₂	+0.80	+470

metals in aqueous environments have been reported.^{12,14} Beer and Smith¹⁶ have produced a series of acyclic ferrocene receptor species (**9–12**) and studied the effects of adding transition metal cations (as hydrated perchlorate or tetrafluoroborate salts) to electrochemical solutions of the receptors. The metal ions may either co-ordinate to the receptors, or alternatively act as acids and protonate them. Protonation causes a shift in the ferrocene oxidation potential (addition of HBF₄ caused a shift of approximately 160 mV with each receptor). Species that are inefficient receptors (*e.g.* **11** with a large donor bite angle) are more likely to be protonated rather than co-ordinate to the transition metal cations (*i.e.* a large shift of approximately 160 mV will be observed). The results are presented in Table 4. Receptors **10** and **11** are protonated on addition of any of the metal cations whereas **12** complexes transition metal cations with anodic shifts up to 115 mV with Ni^{II}. Receptor **12** is capable of co-ordinating to the transition metal *via* the pyridine nitrogen atom (that is not present in receptor **11**).



The electrochemical detection of anionic species is a particular challenge. Anion binding has generally proved to be more challenging (with respect to cations) due to their lower charge to radius ratio, pH sensitivity and range of geometries. Chemically, anions are utilised in many chemical reactions acting as nucleophiles (CN[–]), bases (OR[–]) and redox active centres (S₂O₈^{2–}). The environmental impact of anionic pollutants such as excess nitrates from agricultural fertilisers leads to eutrophication of rivers. Surprisingly then, specific ligands that have

Table 4 Electrochemical shifts (mV) of the ferrocene redox couple in acetonitrile on the addition of metal ion salts as hydrated perchlorates/tetrafluoroborates (n.i. = not investigated). In each case the electrochemical response corresponds to either protonation (p) or complexation of the metal ion (c)

Compound	Free $E_{1/2}/V$	Metal salt ($\Delta E/mV$)				
		Ni ^{II}	Cu ^{II}	Zn ^{II}	Ca ^{II}	Pb ^{II}
9	0.05 ^a	58 ^c	98 ^c	162 ^P	n.i.	n.i.
10	0.027	73 ^c	160 ^P	168 ^P	172 ^P	165 ^P
11	0.040	175 ^P	169 ^P	n.i.	160 ^P	n.i.
12	0.030	115 ^c	105 ^c	75 ^c	158 ^P	n.i.

^a Broad oxidation peak. All $E_{1/2}$ values (quoted for the ferrocene wave) are relative to Ag⁺-Ag in MeCN and are accurate to ± 5 mV.

the capability of optically and/or electrochemically detecting anions are still rare.^{17,18}

Redox-active thiourea or guanidinium hydrogen bond donating receptors containing ferrocene moieties **13–15** have been synthesized by Beer and co-workers.¹⁹ Thiourea containing compound **13** was found not to interact with anions (due to an intramolecular NH...OC hydrogen bond forcing the molecule into an unfavourable conformation). This bond can not form in **14** and **15** and it was found that both these compounds bind anions. Cathodic shifts of up to 125 mV in the ferrocenium-ferrocene redox couple of **15** with H₂PO₄⁻ anions were observed in DMSO, presumably mediated *via* through space interactions. Compound **15** is capable of recognising P₂O₇⁴⁻ anions in methanol-water (a highly competitive solvent mixture) giving a cathodic shift of 70 mV in the ferrocene redox wave.

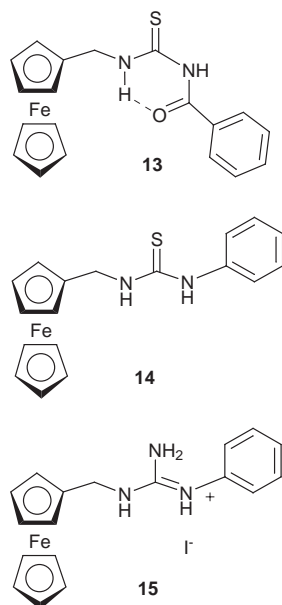

Beer, Martínez-Mañez *et al.*²⁰ have recently achieved the selective electrochemical recognition of sulfate over phosphate and phosphate over sulfate using polyaza ferrocene macrocyclic receptors in aqueous solution.²⁰ Receptors **16–19** can, through an electrochemical response, selectively detect at certain pH values sulfate and phosphate in the presence of competing anions in an aqueous environment. Maximum selective redox cathodic potential shifts of 54 and 50 mV were observed for sulfate and phosphate, using receptors **17** and **19** at pH 4 and 7 respectively.

3 The through bond electrostatic interaction mechanism

One of the earliest examples of electrochemical recognition of cations was reported by Saji⁷ in 1986. He showed that the ferro-

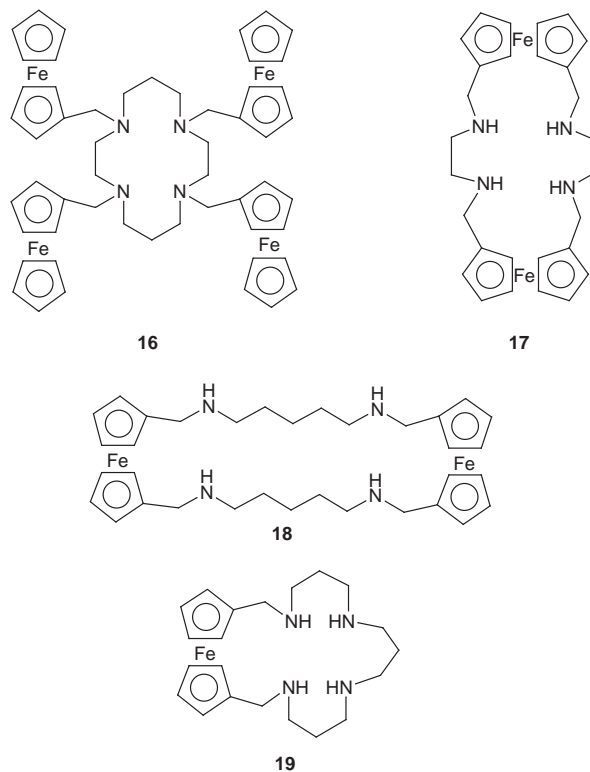

cene crown ether molecule **20** could be used as an electrochemical sensor for alkali metal cations *via* a mixture of through space and through bond interactions (two of the co-ordinating oxygen atoms are attached to the ferrocene cyclopentadienyl ring).

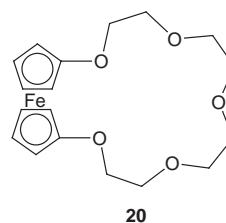

Initially on addition of sodium cations to an electrochemical solution of the ligand, two distinct CV waves were observed, corresponding to the uncomplexed and complexed compound **20** (Fig. 8). The wave at the higher positive potential corresponds to the solution complexed species. The oxidised ferrocene crown ether has a lower binding constant with sodium than the unoxidised receptor due to an electrostatic repulsion of the ferrocenium positive charge and the guest alkali metal cation. For sodium and lithium cations the RCEs ($K_{(1)}/K_{(1)}^+$) were 740 and 72 respectively. This repulsion can be used to switch off cation binding and was utilised by Saji and Kinoshita²¹ to transport alkali metal cations across liquid membranes containing **20** as a carrier (Scheme 2).

In 1990 we reported the synthesis of new redox responsive crown ether molecules **21a** and **21b** that contain a conjugated link between the crown ether unit and a ferrocene redox active centre.²² The electrochemical behaviour of these species was investigated and also the electrochemical behaviour of their analogues with a saturated link between the ferrocene unit and the crown ether.

The changes in the cyclic voltammograms of compound **21a** upon addition of magnesium cations are shown in Fig. 9. The metal cation induced anodic shifts of **21a** and **21b** and also the saturated analogue **22** are shown in Table 5. These results show that significant anodic shifts in the ferrocene oxidation wave result if cations are added to the conjugated receptor systems

Table 5 The electrochemical anodic shifts of the ferrocene oxidation wave of compounds **21a**, **21b** and **22** upon addition of 4 equivalents of cation

	Compound		
	21a	21b	22
$\Delta E(\text{Na}^+)/\text{mV}$	50	65	<5
$\Delta E(\text{K}^+)/\text{mV}$	20	20	<5
$\Delta E(\text{Mg}^{2+})/\text{mV}$	100	110	<20

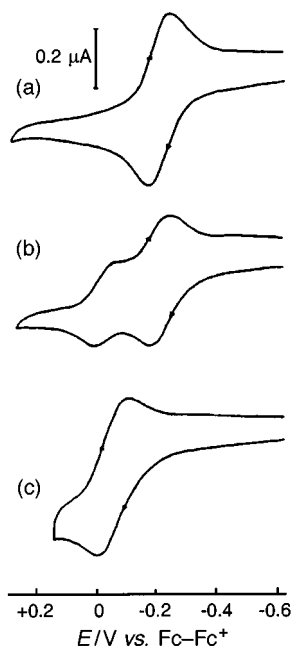
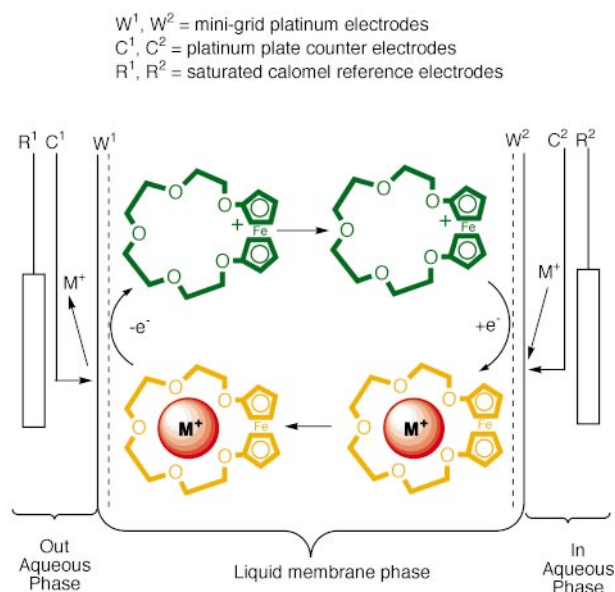

Fig. 8 Cyclic voltammograms for 0.2 mmol dm^{-3} compound **20** (in the presence of 0.1 mol dm^{-3} $n\text{-Bu}_4\text{NPF}_6$ in CH_2Cl_2) in the absence of NaClO_4 (a) and in the presence of 1 mmol dm^{-3} NaClO_4 (partially precipitated) in the course of stirring a solution for (b) 5 min and (c) 1 h. Scan rate 40 mV s^{-1} . (Reprinted with permission from ref. 7, Copyright 1986, Chemical Society of Japan.)



Scheme 2 Transport of alkali metal cations across a liquid membrane using compound **20** as a carrier.

where the π -electron system links the heteroatoms of the ionophore to the redox centre. Much smaller shifts are observed for the saturated analogue suggesting a through bond mode of coupling as the primary mechanism of electrochemical recognition in compounds **21a** and **21b**.

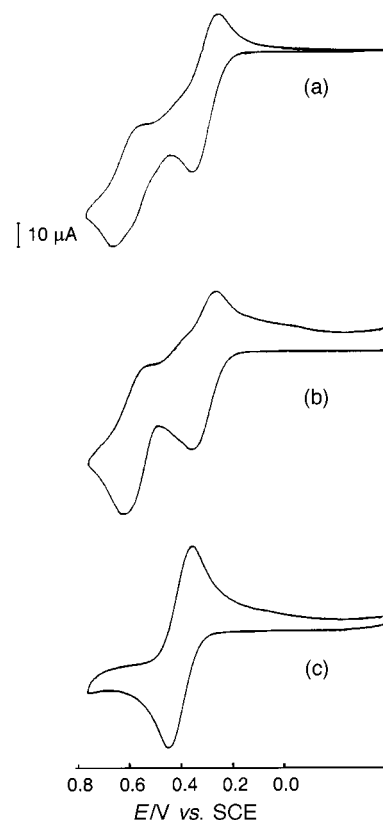
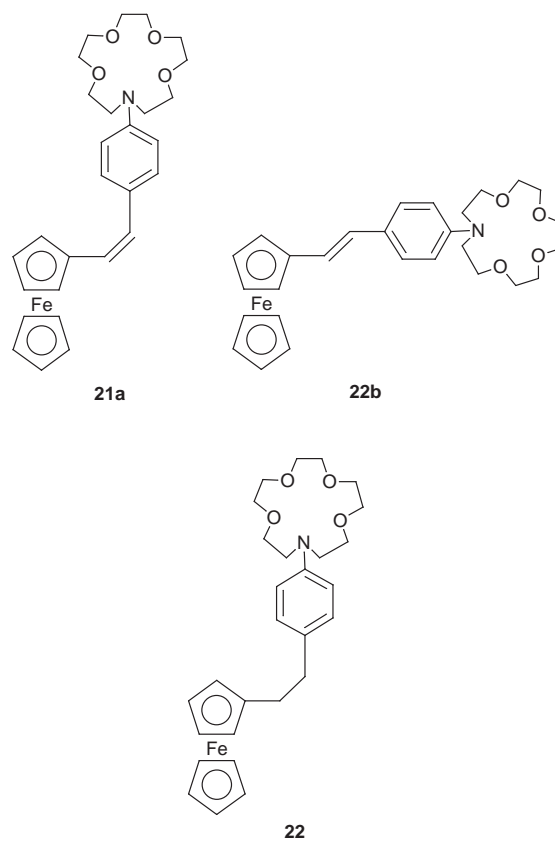
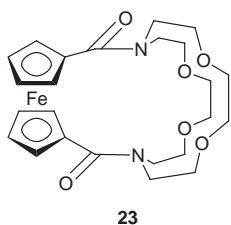

Fig. 9 Cyclic voltammograms for 3 mmol dm^{-3} compound **21** (in the presence of 0.2 mol dm^{-3} $n\text{-Bu}_4\text{NBF}_4$ in CH_2Cl_2): (a) in the absence of Mg^{2+} and in the presence of (b) 0.75 equivalent Mg^{2+} , (c) 1.5 equivalents Mg^{2+} . Scan rate 100 mV s^{-1} . (Reprinted with permission from ref. 22, Copyright 1990, American Chemical Society.)



Hall and Chu²³ have used CV to investigate the co-ordination of alkaline earth and lanthanide metal cations by a series of ferrocene cryptands such as compound **23**. They noted that large anodic shifts of the ferrocenoyl redox couple are produced



with these metal cations and that there exists a broad linear correlation between the $\Delta E_{1/2}$ value and the charge:radius ratio of the cationic guest species (Fig. 10). It has been proposed by Hall that this behaviour is indicative of a through bond interaction (*i.e.* the cations are co-ordinating to the carbonyl group of the amide). There may also be a through space contribution to the electrochemical shift. Alkali metal cations gave only small (<20 mV) anodic shifts with this cryptand.

Whilst examining the co-ordination properties of new di- and tri-aza crown ether ligands containing multiple ferrocene moieties we discovered using ^1H and ^{13}C NMR titration studies that these systems form selective 1:1 stoichiometric complexes with ammonium cations.²⁴ Significant one-wave anodic shifts of the ferrocene redox couple were observed using CV on addition of ammonium to solutions of compounds **24** to **27**, however ligand **28** showed no response, suggesting that the amine nitrogen donor atoms are a prerequisite for ammonium binding

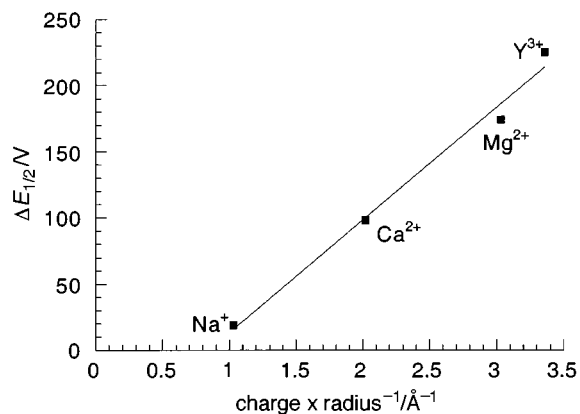

Fig. 10 Plot of $\Delta E_{1/2}$ vs. charge:radius ratio for the complexation of compound **23** with various metal cations.

(Table 6). Substantial anodic shifts of 220 mV were observed with ligand **26** presumably due to a combination of through space interactions and $\text{N-H}^+ \cdots \text{O}=\text{C}$ hydrogen bonds as illustrated in Fig. 11. Compound **27** is also capable of the electrochemical recognition of a cation and an anion (*i.e.* ion pair recognition).²⁵

The through bond mechanism is also effective in communicating anion co-ordination events to redox-active centres. The

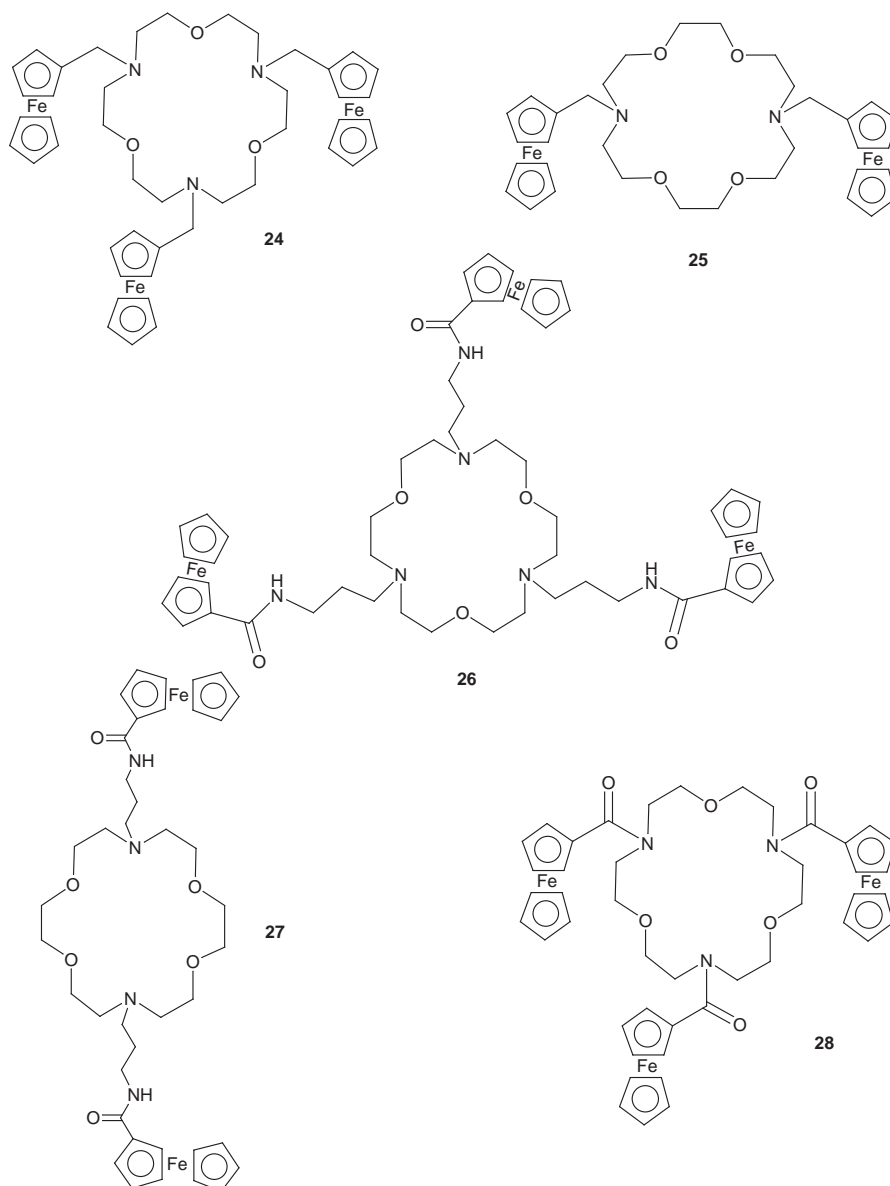

Table 6 Electrochemical data and ammonium cation dependence for compounds **24** to **28**

	Compound				
	24	25	26	27	28
E°/V	+0.43 ^b	+0.41 ^c	+0.62 ^b	+0.54 ^c	+0.67 ^b
$\Delta E_p^a/mV$	90	90	100	100	80
$\Delta E(NH_4^+)/mV$	30	50	220	170	<10
$\Delta E(K^+)/mV$	20	40	50	85	<10
$\Delta E(CH_3NH_3^+)/mV$	—	—	<10	<10	<10
$\Delta E(PhCH_2NH_3^+)/mV$	—	—	<10	<10	<10

^a Solutions were *ca.* 2×10^{-3} mol dm⁻³ in compound, and potentials were determined with reference to the SCE. ^b Three-electron reversible oxidation process. ^c Two-electron reversible process. ^d Separation between anodic and cathodic peak potentials; values for ferrocene under identical conditions ranged from 80 to 90 mV. ^e Shift in respective ferrocenyl oxidation potential produced by presence of guest cation (2 equivalents) added as their thiocyanate salts for potassium and ammonium, and their picrate salts for methylammonium and phenethylammonium.

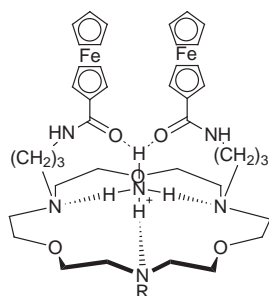

Fig. 11 Proposed lariat co-ordination of NH_4^+ with compound **26**.

tripodal receptors **29** and **30** that contain redox-active positively charged cobaltocenium moieties were synthesized in 65 and 60% yields.¹⁷ The addition of tetrabutylammonium chloride to deuterated acetonitrile ¹H NMR solutions of **29** and **30** resulted in remarkable shifts of the respective protons of both receptors. Of particular note were the substantial downfield shifts of the amide protons ($\Delta\delta = 1.28$ ppm for **29** and 1.52 ppm for **30**) on addition of one equivalent of chloride. These results suggest that a significant $-CO-NH \cdots Cl^-$ hydrogen bonding interaction is contributing to the overall anion complexation process. Subsequent ¹H NMR titration curves suggesting 1:1 stoichiometry with anion complexes of **29** and **30** were found in all cases. Negligible shifts were observed under identical experimental conditions with cobaltocenium hexafluorophosphate ester derivative **31**. However, the simple monoamide-substituted cobaltocenium compound **32** did exhibit some significant solution interactions with halide anions (Table 7) highlighting the importance of the (CONH) amide group in anion binding.

The cathodic shifts of the redox potentials of compounds **29**, **30** and **32** on addition of halide anions are due to the stabilisation of the cobaltocenium cation by the bound anion which causes the redox couple to shift to a more negative potential. Receptor **31** that does not contain the amide CONH group showed no electrochemical response to the addition of anions ruling out the possibility of the cathodic shift being caused by ion-pairing effects. Similar anion induced cathodic perturbations with various ferrocene amide and ruthenium(II) 4,4'-diamide bipyridyl systems have also been noted.^{26,27}

Compounds **33** and **34** contain multiple redox centres (a redox-active ruthenium bipyridyl moiety in addition to a ferrocene or cobaltocenium group). In the presence of chloride anions the amide substituted bipyridyl reduction wave is shifted cathodically by 40 mV for **33** and 90 mV for **34** whereas the ferrocene-ferrocenium redox couple is shifted cathodically by

Table 7 Electrochemical data for compounds **29–32**

	Compound			
	29	30	31	32
$E_{1/2}^a/V$	-0.74 ^b	-0.75 ^b	-0.45	-0.74
$\Delta E(F^-)/mV$	55 ^d	60	<5	—
$\Delta E(Cl^-)/mV$	30	40	<5	30
$\Delta E(Br^-)/mV$	—	—	<5	40

^a Obtained in MeCN solution containing 0.2 mol dm⁻³ *n*-Bu₄NBF₄ as supporting electrolyte. Solutions were *ca.* 2×10^{-3} mol dm⁻³ in ligand, and potentials were determined with reference to the SCE. ^b Three electron reduction process as determined by coulometric experiments. ^c Cathodic shift in reduction potential produced by the presence of anions (4 equivalents) added as their ammonium or butylammonium salts.

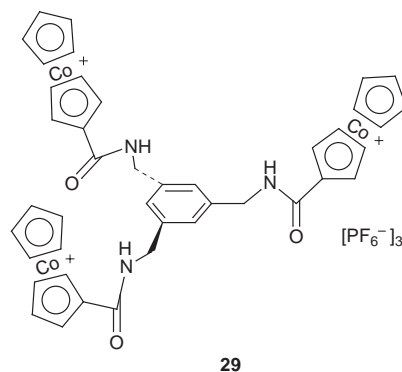

29

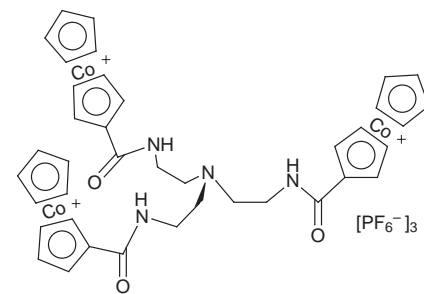

30

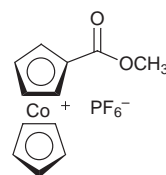

31

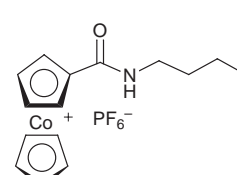

32

60 mV for **33** and the cobaltocene-cobaltocenium couple by 110 mV for **34**.²⁸ The cathodic shift is therefore observed for both redox centres in these receptor species.

4 The conformational change mechanism

Guest induced conformational changes in redox-active molecules may provide a mechanism to induce perturbations in electrochemical behaviour.²⁹ The bipyridinium bis(benzocrown) **35** is one example.³⁰ Earlier work on ferrocene bis(crown ethers) has shown that the amide bond linkage is insulating²² therefore any perturbation of the redox behaviour of **35** will not be caused by through bond interactions. It was confirmed by NMR, UV/Vis techniques and X-ray crystallography (Fig. 12) that this molecule binds Group 1, 2 metal and ammonium cations forming 1:1 intramolecular sandwich complexes with Ba²⁺, K⁺ and NH₄⁺ and 2:1 complexes with Mg²⁺ and Na⁺ with a cation in each crown ether moiety. The formation of a 1:1 sandwich complex forces a significant twist of the

Table 8 Electrochemical data for compound **35** in acetonitrile containing 0.2 mol dm⁻³ *n*-Bu₄NBF₄ as supporting electrolyte (4 equivalents cation salt added)

	Redox couple	
	2 ⁺ /1 ⁺	1 ⁺ /0
<i>E</i> _{1/2} /V	-0.73	-0.87
Δ <i>E</i> ₁ /mV	70	70
Δ <i>E</i> (Ba ²⁺)/mV	45	-10
Δ <i>E</i> (K ⁺)/mV	10	-40
Δ <i>E</i> (NH ₄ ⁺)/mV	10	-40
Δ <i>E</i> (Na ⁺)/mV	-10	30

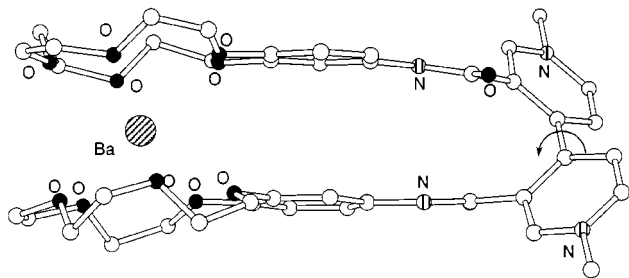
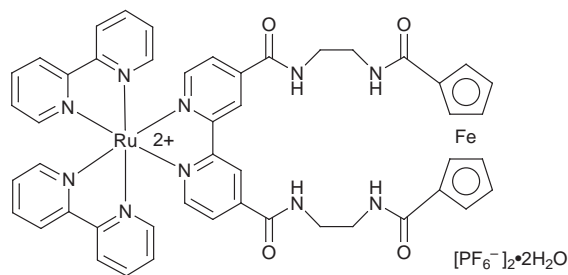
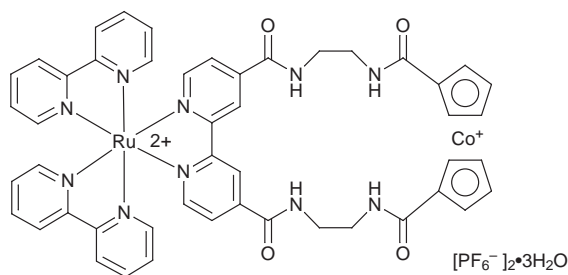

Fig. 12 Crystal structure of the barium complex of receptor **35**.



33



34

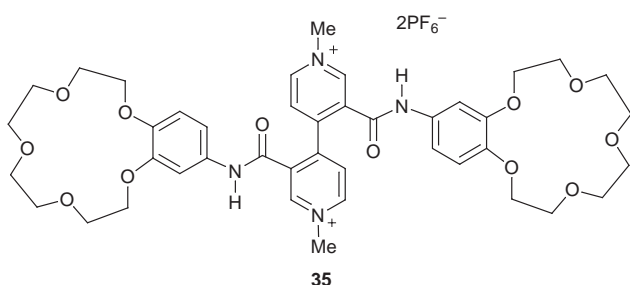

35

4,4'-bipyridinium redox moiety. However formation of the Na⁺ complex does not induce such a dramatic change in the conformation for the 4,4'-bipyridinium unit.

Upon addition of Ba²⁺ cations the 2⁺/1⁺ bipyridinium redox couple was found to shift anodically by 45 mV and the 1⁺/0 couple shift cathodically by 10 mV. Potassium ion and NH₄⁺ produce similar effects (Table 8). However addition of Na⁺ cations caused a small cathodic shift of the 2⁺/1⁺ couple and an

anodic perturbation of the 1⁺/0 couple. These results therefore support the proposal that the conformational change pathway for coupling the complexation and redox reactions is operating in this case.

Interestingly the sulfur linked bis(crown) ligand **36** shows an unprecedented *cathodic* potential shift (60 mV) upon addition of K⁺ cations to the electrochemical solution.³¹ It is believed to be a conformational process that causes the anomalous shift of the ferrocene–ferrocenium redox couple and not a through space or through bond interaction as these would produce the expected anodic potential shift of the ferrocene redox couple. In the presence of K⁺ the receptor forms a 1:1 'sandwich' complex with the cation with the metal ion bound between the two crown ether moieties (this does not occur with the smaller Na⁺ cations). The origin of the effect may therefore be a redirection of the lone pairs of the sulfur donor atoms towards the iron centre upon complexation caused by 'sandwich' formation. This would increase the electron density on the iron causing a cathodic shift (rather than the expected anodic shift) of the redox potential of the ferrocene–ferrocenium couple.

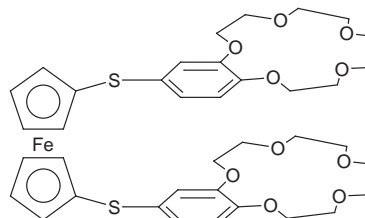

36

5 The direct co-ordination mechanism

Direct co-ordination between the redox centre and guest leads to generally large perturbations in the electrochemical behaviour of the host.

Reducible redox-active nitrobenzene macrocyclic polyether systems have been prepared by a number of groups in particular by Gokel and co-workers^{32,33} who were the first to demonstrate the electrochemical recognition of a sodium cation by such a system. For example the introduction of sodium cations to an electrochemical solution of compound **37** causes the evolution of a new wave on the cyclic voltammogram corresponding to solution complexed species. The redox active nitro group is directly co-ordinated to the sodium cation [Scheme 3(a)]. However the addition of sodium cations to electrochemical solutions of compound **38** has very little effect on the cyclic voltammogram, presumably because the position of the nitro group on the aromatic ring allows no interaction between the sodium cation bound in the macrocycle and the nitro group [Scheme 3(b)]. Therefore the effects of simple through space interactions between the bound cation and nitro aromatic group can be dismissed in both these cases and the pathway for the coupling between the complexation and redox reactions with Na⁺ and **37** is a direct co-ordination route.

Interestingly Gokel has demonstrated the existence of a 'direct co-ordination' coupling pathway between ferrocene cryptand receptor **1** and silver cations. Complexation studies carried out with **1** (as well as other ferrocene cryptand type species) by X-ray crystallography, FAB mass spectral analysis, NMR and UV/vis spectroscopy reveal that compound **1** has an unusual affinity for Ag⁺ cations.³ X-Ray crystallographic determination of the structures of free **1**, sodium and silver complexes were carried out and it was found that the Ag...Fe distance in the silver complex of **1** is only 3.37 Å whereas the Na...Fe distance in the sodium complex is 4.39 Å. This evidence together with the FAB MS and UV spectroscopic data suggests that there may be a co-ordination interaction between the silver cation and the iron present in the ferrocene moiety.

Table 9 Electrochemical data^a for compound **1** in the absence and presence of several cations

Cation	Amount/ equivalents	E°	E°_{ox}	ΔE°	RCE(K/K_+) ^b
none	0	0.216			
Li ⁺	0.5	0.210			
Na ⁺	0.5	0.214	0.402	0.188	3×10^4
K ⁺	0.5	0.224	0.348	0.124	4×10^3
Ca ²⁺	0.5	0.214	0.488 ^c	0.274	2×10^5
Ag ⁺	0.5	0.214	0.496	0.282	2×10^5

^a E° and E°_{ox} are the apparent half-wave potentials of free **1** and the specified metal ion complex respectively. The values are given in V vs. SSCE; ΔE° is the difference between these two values. ^b K and K_+ represent the metal ion binding constants of the reduced and oxidised forms of the ligand respectively. The RCEs given were obtained by optimising the fit of experimental and simulated voltammograms. ^c This redox couple exhibited a marked degree of electrochemical irreversibility.

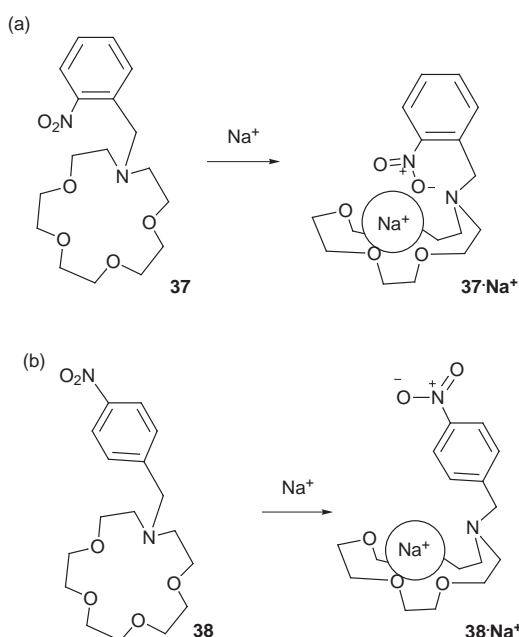

Scheme 3 (a) A direct co-ordination pathway is possible between the binding site of compound **37** and the redox active nitro aromatic moiety whilst it is not available in **38** (b).

The CV of compound **1** is strongly affected by addition of Ag⁺ cations. The behaviour is similar to that observed on addition of sodium cations however the magnitude of the $\Delta E_{1/2}$ value is much larger than that observed with Na⁺ (Table 9).

The $\Delta E_{1/2}$ value with Ag⁺ is larger even than that with Ca²⁺. This is inconsistent with the relatively small charge-to-size ratio of the Ag⁺ cation. The fact that the Ag⁺ ion exerts a much larger effect on the half-wave potential of the ferrocenyl group than would be predicted in terms of its charge-to-size ratio suggests that the bound cation resides closer to the ferrocenyl subunit than the other cations studied. UV/vis Studies suggest this may be due to the ferrocene group acting as a donor to the Ag⁺ cation. Electrochemical experiments were also conducted in an aqueous environment and it was found

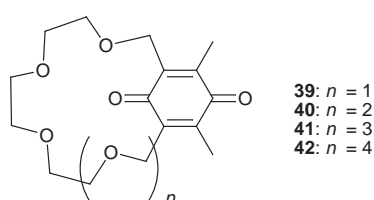

Table 10 Anodic shifts (mV) in the formal reduction potentials of compounds **39–42** upon addition of alkali metal cations

	Compound			
	39	40	41	42
$\Delta E(\text{Li}^+)$	66	56	38	33
$\Delta E(\text{Na}^+)$	68	130	68	67
$\Delta E(\text{K}^+)$	68	162	106	74
$\Delta E(\text{Rb}^+)$	67	138	114	87
$\Delta E(\text{Cs}^+)$	60	117	132	91

that compound **1** can selectively recognise silver cations in water.

Another particularly elegant example of this type of redox/co-ordination coupling are the quinone crown ether species **39–42** synthesized by Cooper and co-workers.³⁴ A number of different size crown ethers were synthesized and the shift of the first reduction potential found for each compound in the presence of excess of alkali metal tosylate. The shifts were all between 60 and 70 mV for **39** but the larger crowns displayed larger shifts (Table 10). In contrast to the expected order of the magnitudes of the shifts from ion pairing effects alone, K⁺ with compound **40** yields the largest potential shift followed by Rb⁺ > Na⁺ > Cs⁺ > Li⁺.

Quinone groups have also been incorporated into ionophoric calixarene skeletons in order to produce amperometric cation sensors. One example, a calixdiquinone ligand **44** that is bridged by a crown ether like a polyglycol strand was synthesized by oxidation of **43** with thallium trifluoroacetate (Scheme 4).³⁵ The

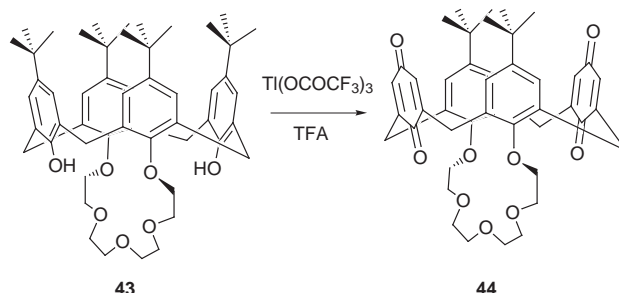

Scheme 4 Synthesis of receptor **44**. TFA = Trifluoroacetic acid.

crystal structure of the potassium perchlorate complex of this receptor is shown in Fig. 13. In this case the quinone groups are co-ordinated directly to the added metal cation which is also bound to the phenolic groups at the lower rim of the calixarene and to the crown ether oxygen atoms. The electrochemical responses of **44** upon addition of cations are shown in Table 11. Particularly notable is the anodic shift of 555 mV observed on addition of barium cations (which to the best of our knowledge is the largest shift so far observed for any redox-active receptor on addition of Group 2 metal cations). Cyclic voltammograms of receptor **44** in the absence and presence of sodium cations are shown in Fig. 14.

6 The interference mechanism

Beer *et al.*³⁶ have used a 1,3,4-tris(ferrocene) substituted calix[5]arene **45** as a neutral guest sensor. Electrochemical studies of the behaviour of **45** have been carried out using cyclic and square wave voltammetric techniques. The receptor itself undergoes two quasi-reversible oxidations at $E_{p1} = +350$ and $E_{p2} = +450$ mV referenced to Ag–Ag⁺. Rotating disk electrode electrochemistry was used to resolve the two oxidation processes and it was found that one ferrocene was oxidised at 350 mV while the other two were oxidised at the larger anodic potential of 450 mV (Fig. 15).

Table 11 Reduction potentials of compound **44** and the anodic shifts in the presence of 1.0 or 2.0 equivalents of different cationic species^a

	E_{pc}/V (vs. Ag–Ag ⁺)	
$E_{1/2}(\text{free})/V$	–1.155	–1.930
$\Delta E(\text{K}^+)/mV$ ^b	210	250
$\Delta E(\text{Na}^+)/mV$ ^b	255	290
$\Delta E(\text{Ba}^{2+})/mV$ ^b	555	^c
$\Delta E(\text{NH}_4^+)/mV$ ^d	405	^c
$\Delta E(\text{n-BuNH}_3^+)/mV$ ^d	355	^c

^a Obtained by both cyclic (100 mV s^{–1}) and square wave (10 Hz, Osteryoung-type) voltammetry in acetonitrile solution containing 0.1 mol dm^{–3} NBu₄BF₄ as supporting electrolyte. Solutions were ca. 1 × 10^{–3} mol dm^{–3} in compound with reference to a Ag–Ag⁺ electrode (330 ± 10 mV vs. SCE) at 21 ± 1 °C. ^b Anodic shift of the reduction waves of (**57**) in the presence of 1.0 equivalent of the respective cationic species added as their perchlorate or hexafluorophosphate salts. ^c The second reduction wave of compound **44** became obscure or disappeared in the presence of more than one equivalent of the respective cations. ^d Anodic shift in the presence of 2.0 equivalents of the respective cations.

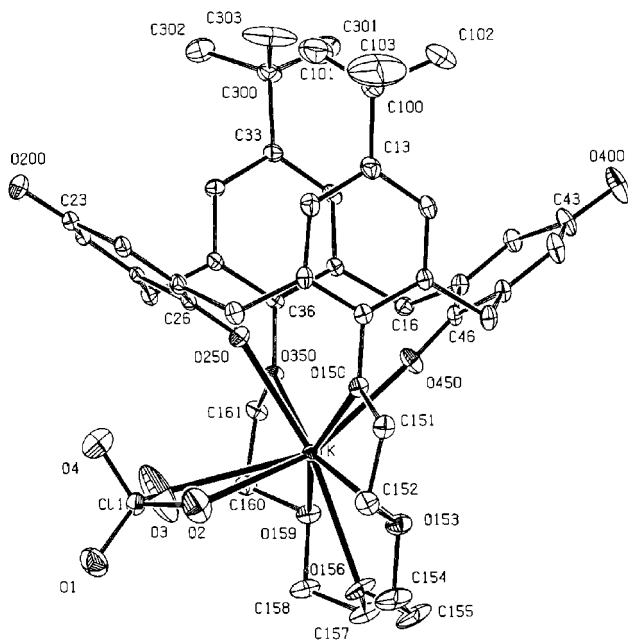
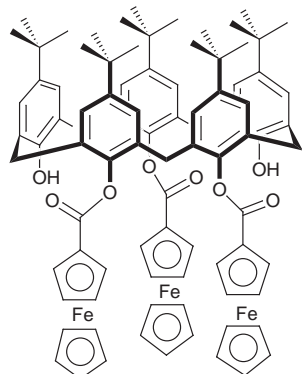

Fig. 13 Crystal structure of the potassium perchlorate complex of receptor **44**. (Reprinted with permission from ref. 35, Copyright 1997, American Chemical Society.)



45

Electrochemical investigations on the effects of addition of potential neutral guests (DMF, DMSO, ethanol) to an electrochemical solution of compound **45** in CH₂Cl₂ show an interesting effect. Addition of polar solvents such as DMF causes the two redox couples to merge. Similar effects were also observed on addition of DMSO or ethanol. However on addition of

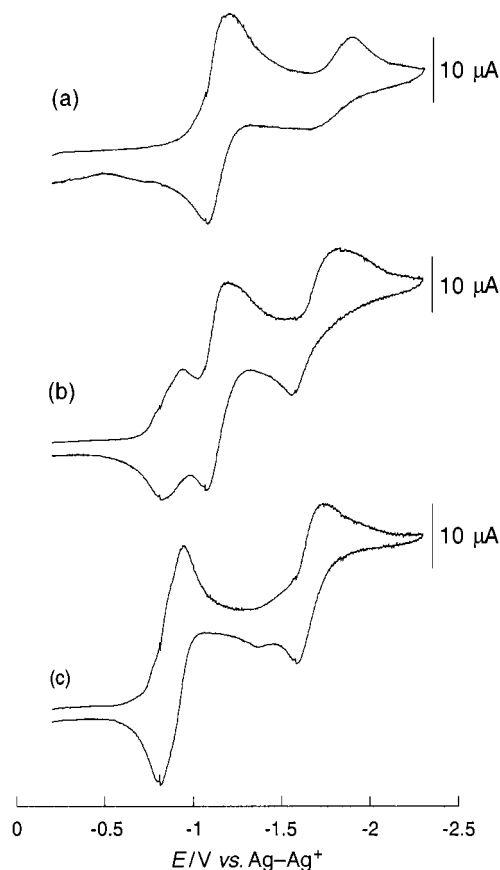

Fig. 14 Cyclic voltammograms of receptor **44** (1.0 × 10^{–3} mol dm^{–3}) in acetonitrile in the absence (a) and the presence of 0.3 equivalent (b) and 1.0 equivalent (c) of sodium cations added as the perchlorate salt. Supporting electrolyte 0.1 mol dm^{–3} n-Bu₄NBF₄. Scan rate: 100 mV s^{–1}. Glassy carbon working electrode.

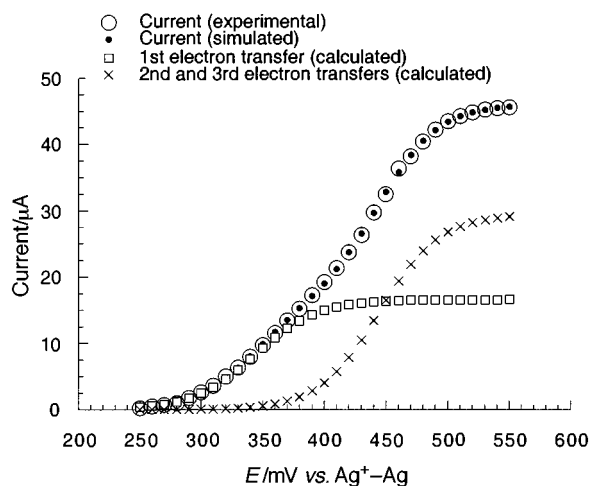

Fig. 15 Computer fit of the Nernst equation to the rotating disk electrode electrochemistry at 121 rpm of compound **45** (5 × 10^{–4} mol dm^{–3}) in CH₂Cl₂ with n-Bu₄NBF₄ (0.1 mol dm^{–3}) as supporting electrolyte [Reprinted with permission from ref. 36(a), Copyright 1995, Royal Society of Chemistry.]

toluene no shifts in the redox couples were observed (Fig. 16). The relative permittivity of CH₂Cl₂ is 8.9. Addition of DMF (ε = 36.7) causes the peaks to merge however the addition of toluene (ε = 2.4) causes little change in the cyclic voltammogram. It may therefore be deduced that the splitting of the peak in CH₂Cl₂ alone is at least partially due to the interaction between the ferrocene moieties. The decrease in the interaction upon addition of the higher relative permittivity solvent implies that the polar solvent is interposing itself between the ferrocene

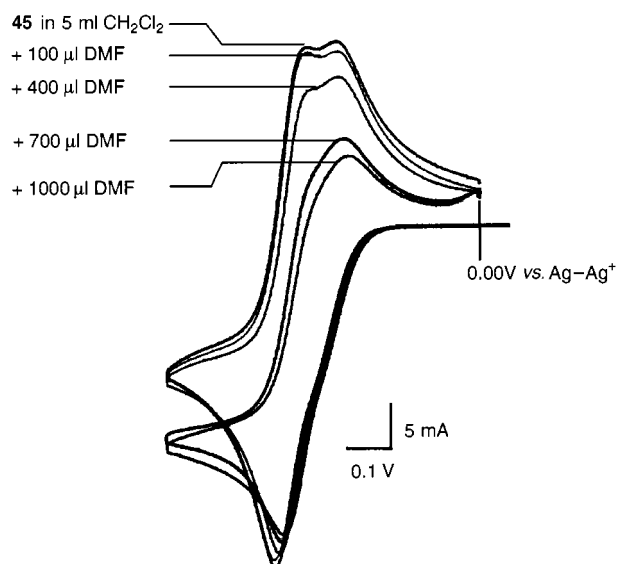

Fig. 16 The two redox processes become more equivalent upon addition of DMF to the solution of compound **45** ($5 \times 10^{-4} \text{ mol dm}^{-3}$) in CH_2Cl_2 with $n\text{-Bu}_4\text{NBF}_4$ (0.1 mol dm^{-3}) as supporting electrolyte.

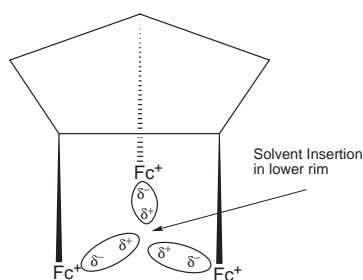

Fig. 17 Insertion of polar guest species into the lower rim of compound **45** causing a decrease in the interaction between the ferrocene groups.

moieties (Fig. 17). As the relative permittivity of the interposed solvent increases, the shielding between the ferrocene centres increases due to the guest's higher polarisability. The inclusion of the more highly polarisable guest therefore interferes with the electrochemical interactions present in the host so producing an electrochemical response.

7 Conclusion

This perspective has covered recent advances in the electrochemical recognition of cations, anions and neutral guest species by redox-active receptor molecules. The mechanisms of complexation–redox coupling *via* through bond, through space and direct co-ordination have been highlighted in each case. Over recent years there have been few papers reporting examples of receptors employing the conformational change mechanism. The interference mechanism also remains to be exploited. This is clearly an area of electrochemical molecular recognition that is full of opportunity for the interested chemist. The electrochemical recognition of ion pairs²⁵ and neutral guests³⁷ is another area that remains to be fully explored. We hope to see the emergence, over the next few years, of ‘real-world’ devices based on the concepts illustrated here.

Acknowledgements

We thank the EPSRC, the Royal Society, Kodak Limited, British Petroleum, Serpentix, MediSense and the Ministry of Defence

for financial support. Special thanks go to Dr M. G. B. Drew (University of Reading) for his many crystal structure determinations.

References

- 1 D. R. Crow, *Principles and Applications of Electrochemistry*, Blackie, London, 1994.
- 2 P. L. H. M. Cobben, R. J. M. Egberink, J. G. Bomer, P. Bergveld, W. Verboom and D. N. Reinhoudt, *J. Am. Chem. Soc.*, 1992, **114**, 10573.
- 3 J. C. Medina, T. T. Goodnow, M. T. Rojas, J. L. Atwood, B. C. Lynn, A. E. Kaifer and G. W. Gokel, *J. Am. Chem. Soc.*, 1992, **114**, 10583.
- 4 P. L. Boulas, M. Gomez-Kaifer and L. Echegoyen, *Angew. Chem., Int. Ed. Engl.*, 1998, **37**, 216.
- 5 H. Plenio and R. Diodone, *J. Organomet. Chem.*, 1995, **492**, 73.
- 6 G. Charlot, J. Badoz-Lambling and B. Trémillion, in *Electrochemical Reactions*, Elsevier, Amsterdam, 1962.
- 7 T. Saji, *Chem. Lett.*, 1986, 275.
- 8 H. Plenio and R. Diodone, *Inorg. Chem.*, 1995, **34**, 3964.
- 9 J.-P. Bourgeois, L. Echegoyen, M. Fibboli, E. Pretsch and F. Diederich, *Angew. Chem., Int. Ed. Engl.*, 1998, **37**, 2118.
- 10 P. D. Beer, Z. Chen and A. J. Pilgrim, *J. Chem. Soc., Faraday Trans.*, 1995, 4331.
- 11 P. D. Beer, Z. Chen and A. J. Pilgrim, *J. Electroanal. Chem.*, 1998, **444**, 209.
- 12 P. D. Beer, Z. Chen, M. G. B. Drew, J. E. Kingston, M. I. Ogden and P. Spencer, *J. Chem. Soc., Chem. Commun.*, 1993, 1046.
- 13 M. E. Padilla-Tosta, R. Martínez-Mañez, T. Pardo, J. Soto and M. J. L. Tendo, *Chem. Commun.*, 1997, 887.
- 14 J. M. Lloris, R. Martínez-Mañez, T. Pardo, J. Soto and M. E. Padilla-Tosta, *Chem. Commun.*, 1998, 837.
- 15 H. Plenio and C. Aberle, *Chem. Commun.*, 1998, 2697.
- 16 P. D. Beer and D. K. Smith, *J. Chem. Soc., Dalton Trans.*, 1998, 417.
- 17 P. D. Beer, C. Hazlewood, D. Heseck, J. Hodacova and S. E. Stokes, *J. Chem. Soc., Dalton Trans.*, 1993, 1327.
- 18 (a) P. D. Beer, *Chem. Commun.*, 1996, 689; (b) P. D. Beer, P. A. Gale and Z. Chen, *Adv. Phys. Org. Chem.*, 1998, **31**, 1.
- 19 P. D. Beer, M. G. B. Drew and D. K. Smith, *J. Organomet. Chem.*, 1997, **543**, 259.
- 20 P. D. Beer, J. Cadman, J. M. Lloris, R. Martínez-Mañez, M. E. Padilla-Tosta, T. Pardo, D. K. Smith and J. Soto, *J. Chem. Soc., Dalton Trans.*, 1999, 127.
- 21 T. Saji and I. Kinoshita, *J. Chem. Soc., Chem. Commun.*, 1986, 716.
- 22 P. D. Beer, C. Blackburn, J. F. McAleer and H. Sikanyika, *Inorg. Chem.*, 1990, **29**, 378.
- 23 C. D. Hall and S. Y. F. Chu, *J. Organomet. Chem.*, 1995, **498**, 221.
- 24 P. D. Beer, D. B. Crowe, M. I. Ogden, M. G. B. Drew and B. Main, *J. Chem. Soc., Dalton Trans.*, 1993, 2107.
- 25 P. D. Beer, Z. Chen and M. I. Ogden, *J. Chem. Soc., Faraday Trans.*, 1995, 295.
- 26 P. D. Beer, Z. Chen, A. J. Goulden, A. Graydon, S. E. Stokes and T. Wear, *J. Chem. Soc., Chem. Commun.*, 1993, 1834.
- 27 P. D. Beer, A. R. Graydon, A. O. M. Johnson and D. K. Smith, *Inorg. Chem.*, 1997, **36**, 2112.
- 28 P. D. Beer, F. Szemes, V. Balzani, C. M. Salà, M. G. B. Drew, S. W. Dent and M. Maestri, *J. Am. Chem. Soc.*, 1997, **119**, 11864.
- 29 A. Gourdon, *New J. Chem.*, 1992, **16**, 953.
- 30 P. D. Beer, Z. Chen, A. Grieve and J. Haggitt, *J. Chem. Soc., Chem. Commun.*, 1994, 2413.
- 31 P. D. Beer, J. P. Danks, D. Heseck and J. F. McAleer, *J. Chem. Soc., Chem. Commun.*, 1993, 1735.
- 32 A. Kaifer, L. Echegoyen, D. A. Custowski, D. M. Crolis and G. W. Gokel, *J. Am. Chem. Soc.*, 1983, **105**, 7168.
- 33 A. Kaifer, D. A. Custowski, L. Echegoyen, V. J. Gatto, R. A. Schultz, T. P. Cleary, C. R. Morgan, D. M. Goli, A. M. Rios and G. W. Gokel, *J. Am. Chem. Soc.*, 1985, **107**, 1958.
- 34 M. Delgado, J. R. E. Wolf, J. R. Hartman, G. McCafferty, R. Yagbasan, S. C. Rawle, D. J. Watkin and S. R. Cooper, *J. Am. Chem. Soc.*, 1992, **114**, 8983.
- 35 P. D. Beer, P. A. Gale, Z. Chen, M. G. B. Drew, J. A. Heath, M. I. Ogden and H. R. Powell, *Inorg. Chem.*, 1997, **36**, 5880.
- 36 (a) P. D. Beer, Z. Chen, M. G. B. Drew and P. A. Gale, *J. Chem. Soc., Chem. Commun.*, 1995, 1851.; (b) P. D. Beer, P. A. Gale, Z. Chen and M. G. B. Drew, *Supramol. Chem.*, 1996, **7**, 241.
- 37 J. D. Carr, L. Lambert, D. E. Hibbs, M. B. Hursthouse, K. M. A. Malik and J. H. R. Tucker, *Chem. Commun.*, 1998, 1649.